

# **FC-757AT**

# **INSTRUCTION**

# **MANUAL**

**YAESU MUSEN CO., LTD.**

C.P.O. BOX 1500

TOKYO, JAPAN

## THE FC-757AT FULLY AUTOMATIC HF ANTENNA TUNER



The FC-757AT is a multi-functional microprocessor-controlled RF handling device designed to provide for all of the antenna switching, impedance matching and RF metering requirements of an amateur station, with maximum power handling capability of 150 watts.

Designed to match the FT-757GX All Mode HF Transceiver, which provides automatic band-switching and power control functions via the supplied control cable, the FC-757AT can also be automatically controlled by the FT-980 Transceiver via an optional control cable. Manual power and bandswitching controls are also provided for use when the FC-757AT is powered by an independent DC source and used with any other HF transceiver, transmitter or receiver.

The 8-bit microprocessor allows for fast, accurate automatic impedance matching utilizing a modified pi-L network. A directional CM coupler at the transmitter side of the network and an RF pickup at the antenna side ensure a wide range of SWR acceptance, and final SWR to the transmitter better than 1.5:1 for impedances in that range. Manual matching is also possible for particularly difficult situations, or when matching for receiving only.

Two antenna jacks are provided, along with controls for remote automatic and manual selection of up to five antennas in total when the FC-757AT is used with the optional FAS-1-4R Remote Antenna Selector. An internal 50-ohm dummy load is included in the FC-757AT, along with an in-line RF wattmeter and a self-calculating (automatic) SWR meter.

The particular antenna selected for operation on a particular band, along with the settings of the matching network, are digitally encoded and stored in lithium-backed RAM by the microprocessor, so that when that band is selected again, the same antenna and matching settings are automatically reset quickly. Thus no extra time is required for rematching.

During operation, any change in frequency that causes the SWR to rise above 1.5:1 will cause the auto-tune system to automatically rematch the load if desired, and the new settings will then be automatically written into memory for that band.

Please read this manual carefully before operating your FC-757AT, to ensure optimum performance and enjoyment of its many features.

# SPECIFICATIONS

## MATCHING SECTION

### Frequency range (TX, w/auto band select):

- 1.8 – 2.0 MHz
- 3.5 – 4.0 MHz
- 7.0 – 7.5 MHz
- 10.0 – 10.5 MHz
- 14.0 – 14.5 MHz
- 18.0 – 18.5 MHz
- 21.0 – 21.5 MHz
- 24.5 – 25.0 MHz
- 28.0 – 29.9 MHz

### Input impedance:

50Ω

### Output impedance range:

- 10 – 250Ω
- 25 – 100Ω (1.8 – 2.0 MHz)

### Maximum RF power:

150W

### Insertion loss:

less than 0.5 dB

### Motor stop SWR:

1.5:1 or better

### SWR meter scale range:

1:1 – 3:1

### In-line power meter ranges:

15W, 150W f/s

## DUMMY LOAD

### Impedance:

50Ω

### Power dissipation:

100W CW (less than 30 sec.)

## POWER REQUIREMENTS

### Supply voltage:

13.5V DC ±10%

### Current:

300 mA max.  
(400 mA w/FAS-1-4R)

### Size:

(W) 238 x (H) 94 x (D) 241 mm

### Weight:

Approximately 3.7 kg

Specifications subject to change without notice or obligation

## Supplied Accessories

Connection Cable A	(T9100160A)	1
5D-2V Coax w/type M connectors		
Connection Cable B	(T9015099)	1
Control Cable C for FT-757GX	(T9101292)	1

## Optional Accessories

Control Cable for FT-980	(D4000014)	1
FAS-1-4R Remote Antenna Selector	(D3000198)	1

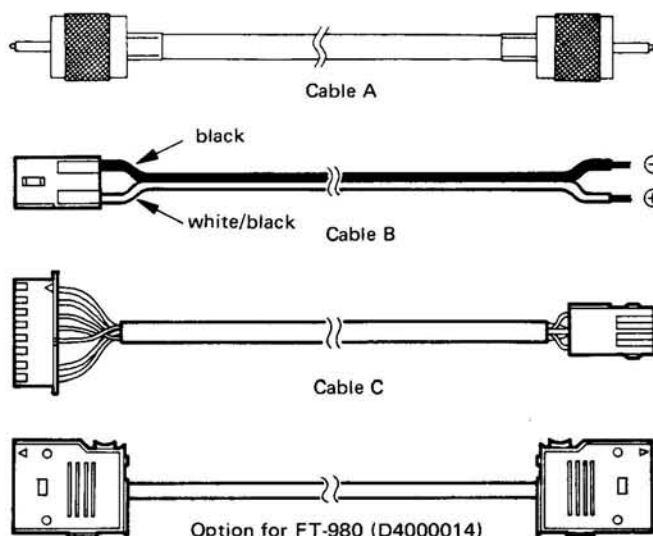

## FRONT PANEL CONTROLS

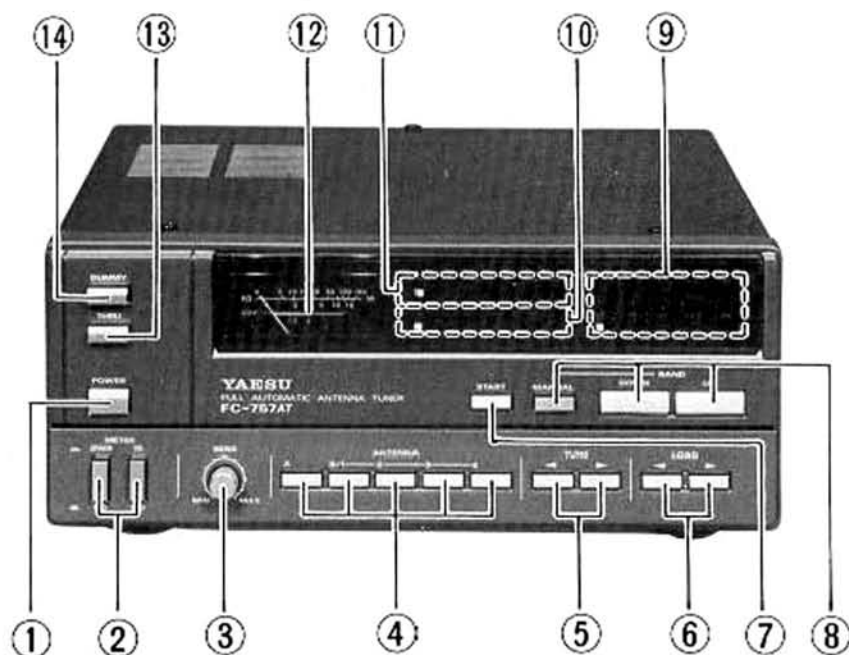

### ① POWER Switch

When this switch is set to the off (out) position, the RF INPUT jack is connected directly to the ANT A jack, and the Tuner is removed from the circuit. However, tuner settings (and antenna selections) stored in the memory are retained by the internal lithium battery memory backup.

If the FC-757AT is used with a transceiver designed to control the tuner automatically, such as the FT-757GX or FT-980, power to the Tuner is switched automatically via the interconnecting control cable. In this case, the POWER switch on the FC-757AT can be left in the on (depressed) position, and the on/off function will be performed by the transceiver POWER switch.

### ② METER Switches (SWR/PO and 15/150)

These two-position switches select the function and full scale RF power range of the meter. In the PO (out) position, the SWR/PO switch causes the meter to indicate forward power output in watts, with the 15/150 switch position determining the related meter range.

In the SWR (depressed) position, the SWR/PO switch activates the self-calculating SWR system, which indicates SWR on the (lower) meter scale when the 15/150 switch is set to the correct position corresponding to the amount of RF power applied from the transmitter (if at least 10–15 watts).

### ③ SENSitivity Control

This potentiometer adjusts the SWR threshold level at which the automatic tuning system automatically starts and stops its tuning procedure. If the SWR of the antenna system is close to 1.5:1, this control should be set fully clockwise for maximum sensitivity to SWR. However, if the SWR is high, the SWR null may be too sharp for the automatic sensing circuitry to notice, in which case the SENS control must be set further counterclockwise.

For manual tuning and mobile operation or other conditions where the SWR continually fluctuates, the SENS control should be set fully counterclockwise. Also, once auto-tuning has been completed and the tuner settings are to be retained in memory, set this control fully counterclockwise.

### ④ ANTENNA Buttons

These five momentary contact buttons are used to select antennas. The first button (A) at the left will select the ANT A jack on the rear panel. This is also the default condition, and thus this selection is made automatically while power is off.

Ordinarily, any of the four remaining buttons will select the antenna connected to the ANT B jack on the rear panel. However, when the FC-757AT is used with the FAS-1-4R Remote Antenna Selector, each of these buttons will select, via the interconnecting control cable, one of the four jacks

at the output of the FAS-1-4R. RF power then flows from the Tuner through the feedline connected to the ANT B jack to the Remote Antenna Selector, where it is directed to the selected antenna. Once the correct antenna has been selected for the band in use, this antenna selection data will be stored in memory, so that after operating on another band and returning to the original band, the original antenna will be re-selected automatically.

### ⑤ TUNE Buttons

These two push buttons are used for manual antenna tuning, when the SENS control is set fully counterclockwise. Press (and hold) the ◀ button to increase the capacitance between the output terminal of the pi-network and ground (usually referred to as "load" capacitance). Capacitance will increase to maximum (290 pF) and stop. Push the ▶ button to decrease capacitance to minimum. The optimum value of capacitance set by these buttons must be determined by watching the meter (set for PO), and tuning for maximum forward power. The capacitance set manually will be stored in the memory for that band.

### ⑥ LOAD Buttons

These two push buttons are used for manual antenna tuning, along with the TUNE buttons, when the SENS control is set fully counterclockwise. The manner of operation is the same as for the TUNE buttons, but the capacitance which is adjusted by the LOAD buttons is actually the capacitance in series with the load at the output of the tuner, up to a maximum of 430 pF. The capacitance set manually will be stored in memory for that band.

### ⑦ START Button

This momentary contact button activates the auto-tune system manually. Normally, when the operating band is changed, the Tuner will automatically adjust itself for the same antenna selection and matching impedance set the last time that band was used. Press the START button to retune if SWR is now too high. Manual restart, caused by pressing this button, can be used to force the auto-tune system to retune at any time.

### ⑧ BAND (MANUAL, DOWN and UP Buttons)

The two-position MANUAL button enables the DOWN and UP keys for manual band changing, when depressed (the band to which the Tuner is set to operate is indicated by the ten LEDs above these buttons). When used with a transceiver designed to control the FC-757AT, such as the FT-757GX or FT-980, the MANUAL button should be set to the undepressed position to allow automatic band selection in the Tuner by the transceiver, via the interconnecting control cable.

When using the FC-757AT with a transceiver that does not have provision for Tuner band control, or when it is desired to override the automatic band-selecting function, set the MANUAL button to the depressed position. The DOWN and UP keys can then be used to step through the bands.

Note that the tuner settings are automatically stored in memory on each band, so that when the Tuner is reset to a band previously used, the variable capacitors and antenna select relays will automatically reset to the positions to which they were set when last operating on that band.

When automatic band selection by the transceiver is used to select the 1.8 MHz band, the Tuner will automatically be set to the 1.8L band position. However, if the Tuner is unable to find the dip in SWR, it may be necessary to press the MANUAL button, and then the UP key, to switch to the 1.8H band position.

### ⑨ Band Indicators

One of these ten green LEDs will be lit to indicate the selected MHz band to which the FC-757AT is set.

### ⑩ Antenna Selection Indicators

One of these five LEDs will be lit to indicate which antenna is selected for operation. The ANT A LED is green, and the others are yellow.

### ⑪ Tuner Status Indicators (READY, WAIT and WARNING)

The green READY LED is lit whenever it is alright to transmit. The yellow WAIT LED lights after changing bands, while the Tuner is resetting the variable capacitors to their memorized positions,

and also during auto-tuning. Except during auto-tuning, the transmitter should not be activated until the WAIT LED extinguishes and the READY LED lights.

If the red WARNING LED lights during transmission, a severe mismatch is present at the selected antenna jack. Stop transmitting immediately, and check for the cause of the problem (such as open or short circuits in the feedline).

## ⑫ Meter

The meter indicates approximate RF output power in watts on the upper scale, with the top half corresponding to the "150" position of the 15/150 METER button, and the lower half corresponding to the "15" position of the button (the SWR/PO METER button must be set to the PO position).

The lower scale of the meter indicates antenna SWR during transmission, when the SWR/PO METER button is set to the SWR (depressed) position. This SWR indication is calculated automatically by the internal circuitry, and is therefore fairly independent of the actual RF power applied to the tuner by the transmitter, as long as it is at least 10–15 watts.

## ⑬ THRU Switch

When set to the depressed position, this switch bypasses the Tuner circuit from the RF line. This can be used for receiving on frequencies that are outside of the matching range of the FC-757AT. In the undepressed position, the Tuner is in the RF line.

## ⑭ DUMMY Switch

When in the depressed position, this switch connects the INPUT from the transmitter to the internal dummy load, leaving only the CM coupler for the metering system in the circuit. Therefore, the antenna selection and THRU switches, and the tuning system, will not affect operation into the dummy load. The dummy load impedance is 50 ohms, and power handling capability is 100 watts CW for 30 seconds maximum, after which it should be allowed to cool for one minute. The DUMMY switch must be in the undepressed position to use the tuning system or to deliver power to the antenna.



## REAR PANEL CONNECTIONS

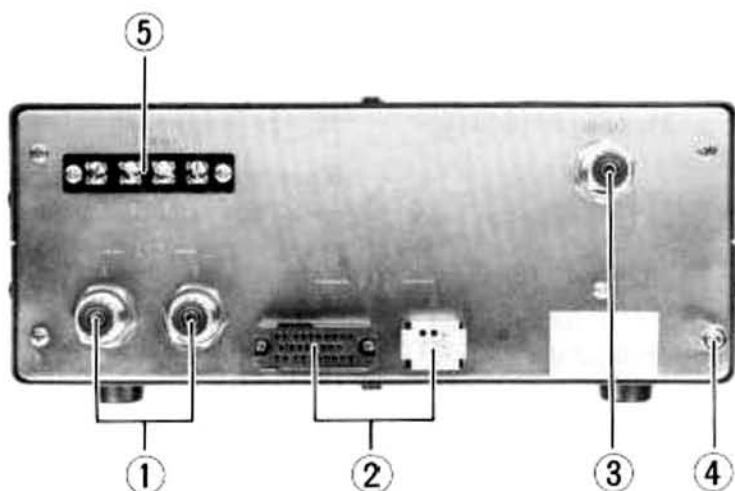

### ① ANT A, B

These type M coaxial jacks are for connection of the antenna system(s). The ANT A jack is automatically selected when the DC power to the Tuner is switched off, or when the front panel POWER switch is off. The ANT B jack is for connection of an alternate or secondary antenna system, or for the feedline to the optional FAS-1-4R Remote Antenna Selector.

### ② ACC 1, 2

The blue 28-pin ACC 1 connector accepts power and band selection signals from the FT-980 Transceiver via the optional interconnecting cable.

The white molex ACC 2 connector accepts power and band selection signal from the FT-757GX Transceiver via supplied interconnecting cable C. When the FC-757AT is used with a transceiver that is not designed for automatic band control, DC power must be supplied to this connection via supplied DC power cable B. Power requirements are 12 to 15V at 300 mA, or 400 mA if the FAS-1-4R is also used.

### ③ INPUT

This type M coaxial jack is for connection to the antenna jack on the transceiver, via supplied connection cable A. RF power applied here should be limited to about 150 watts, or 100 watts when the internal dummy load is selected.

### ④ GND Binding Post

For optimum performance and safety, connect this terminal to a good earth ground by the shortest path possible, using heavy braided cable.

### ⑤ REMOTE Terminal Strip

These terminals provide the antenna selecting signals for the FAS-1-4R when the appropriate control cable is connected here.

# INSTALLATION

## ANTENNA CONSIDERATIONS

The FC-757AT and FAS-1-4R Remote Antenna Selector are designed for unbalanced RF feedlines. For antennas that require balanced feed, or for connecting balanced feedlines to this equipment, balun transformers are recommended. Such baluns should be designed to provide the nearest possible match to 50 ohms at the unbalanced side, and then 50-ohm coax should be used to make connections to the equipment. In such cases, where a portion of the feedline is open-wire type, the length of coax used should be as short as possible in relation to the open-wire portion, to minimize feedline loss in high SWR conditions.

While the range of SWRs that the FC-757AT is able to match is quite wide, antenna systems that are very far from resonance at the operating frequency may present too high an SWR to permit proper matching with the Tuner. In such cases it is best to retune the antenna itself, or use it only on the bands where it matches easily, installing another antenna for the desired band. If the Tuner is not able to bring the SWR down below 3:1, attempting to transmit will result in an automatic reduction of power in the transmitter, high power loss in the coaxial feedline, and unfavorable stress (high voltage) on the RF components in the Tuner. Operation under such conditions is not recommended.

The FAS-1-4R is designed to allow remote selection of up to four additional antennas, with only a single feedline and control cable from the FC-757AT to the FAS-1-4R. Once set, the correct antenna for each band is selected automatically whenever the operating band is changed in the Tuner.

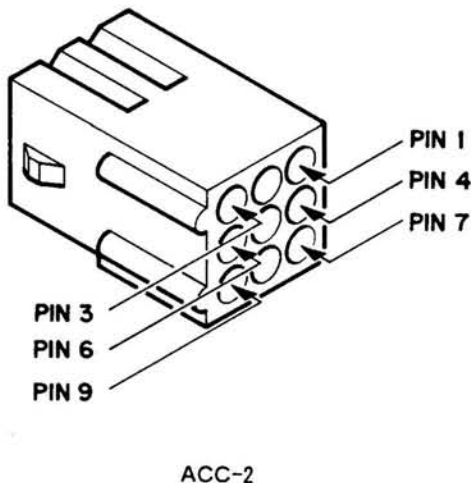

## INTERCONNECTIONS

Figures 1 through 4 on the following pages illustrate the interconnections between various models of HF equipment and the FC-757AT, and optional FAS-1-4R. When setting up the station, be sure to install the earth ground connections to the FC-757AT and Transceiver, as well as the cables shown.

Figures 1 and 2 illustrate the interconnections with the FT-757GX and FT-980, respectively. Control cable C, for connecting the FT-757GX to the FC-757AT, is supplied with the Tuner. However, the control cable required for connecting the FT-980 ACC-1 jack to the FC-757AT (for automatic power switching and band selection) is optional.

Figures 3 and 4 illustrate the interconnections of the FC-757AT when used with equipment that is not designed to provide power and automatic bandswitching signals for the Tuner. In these cases, supplied DC power cable B is used to connect the Tuner to a separate source of DC (12 to 15V at 300 mA, or 400 mA with the FAS-1-4R), and power switching and band selection are controlled only by the buttons on the front panel of the FC-757AT. Of course the FT-757GX or FT-980 may also be used in this way, without the automatic functions.

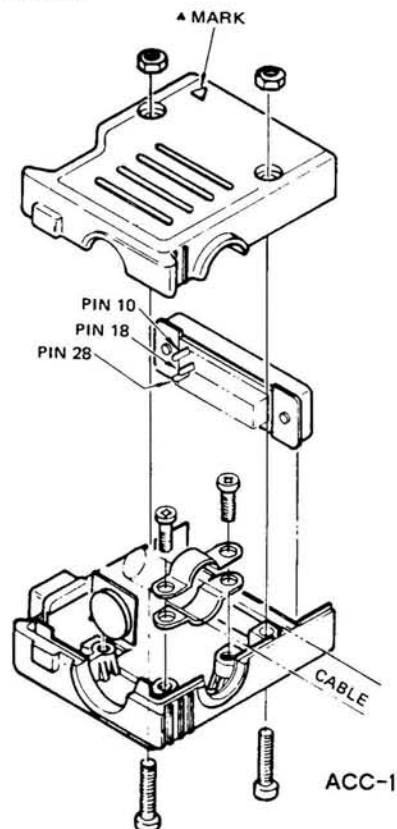

FIGURE 1.  
FC-757AT  
AND FT-757GX

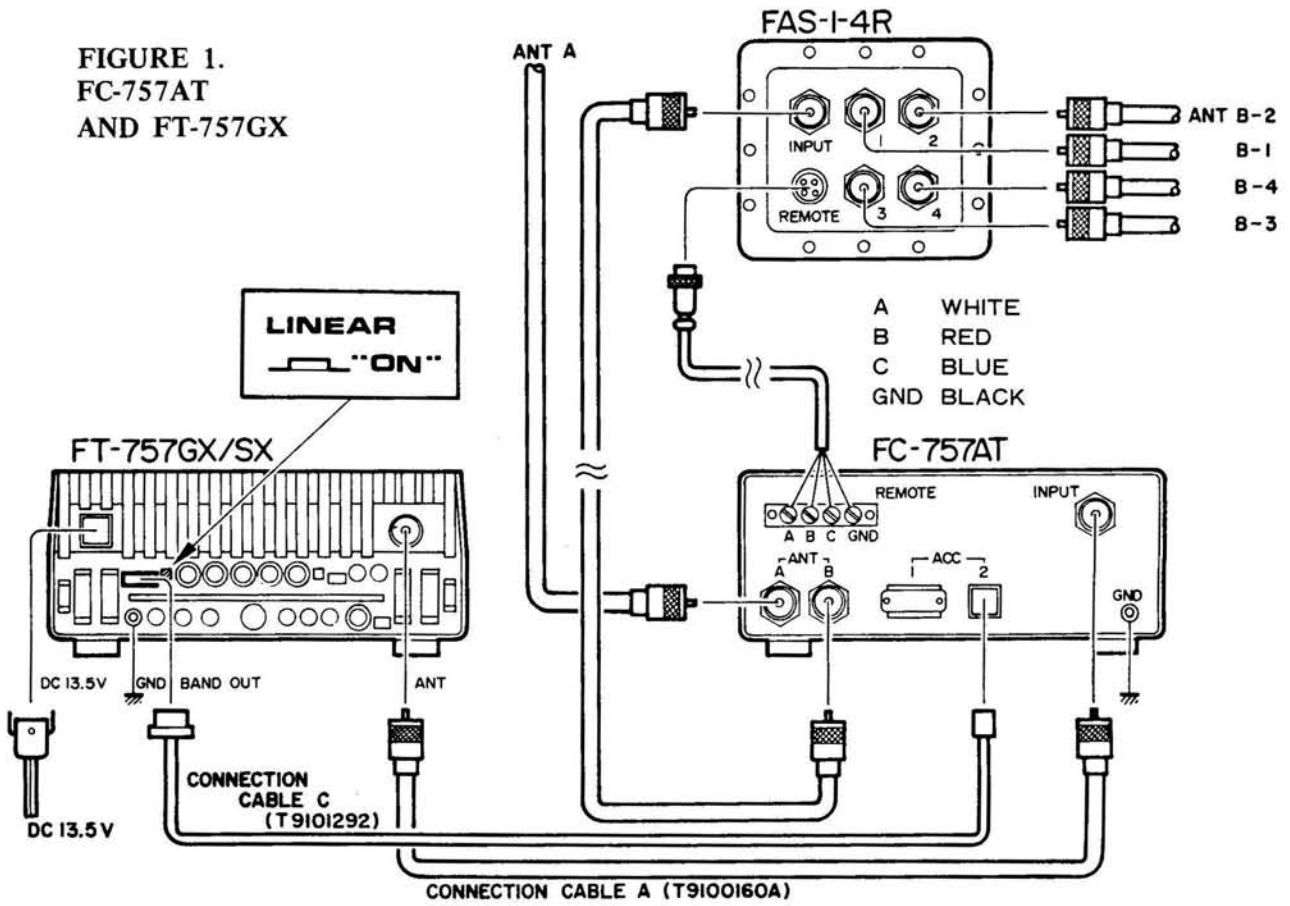
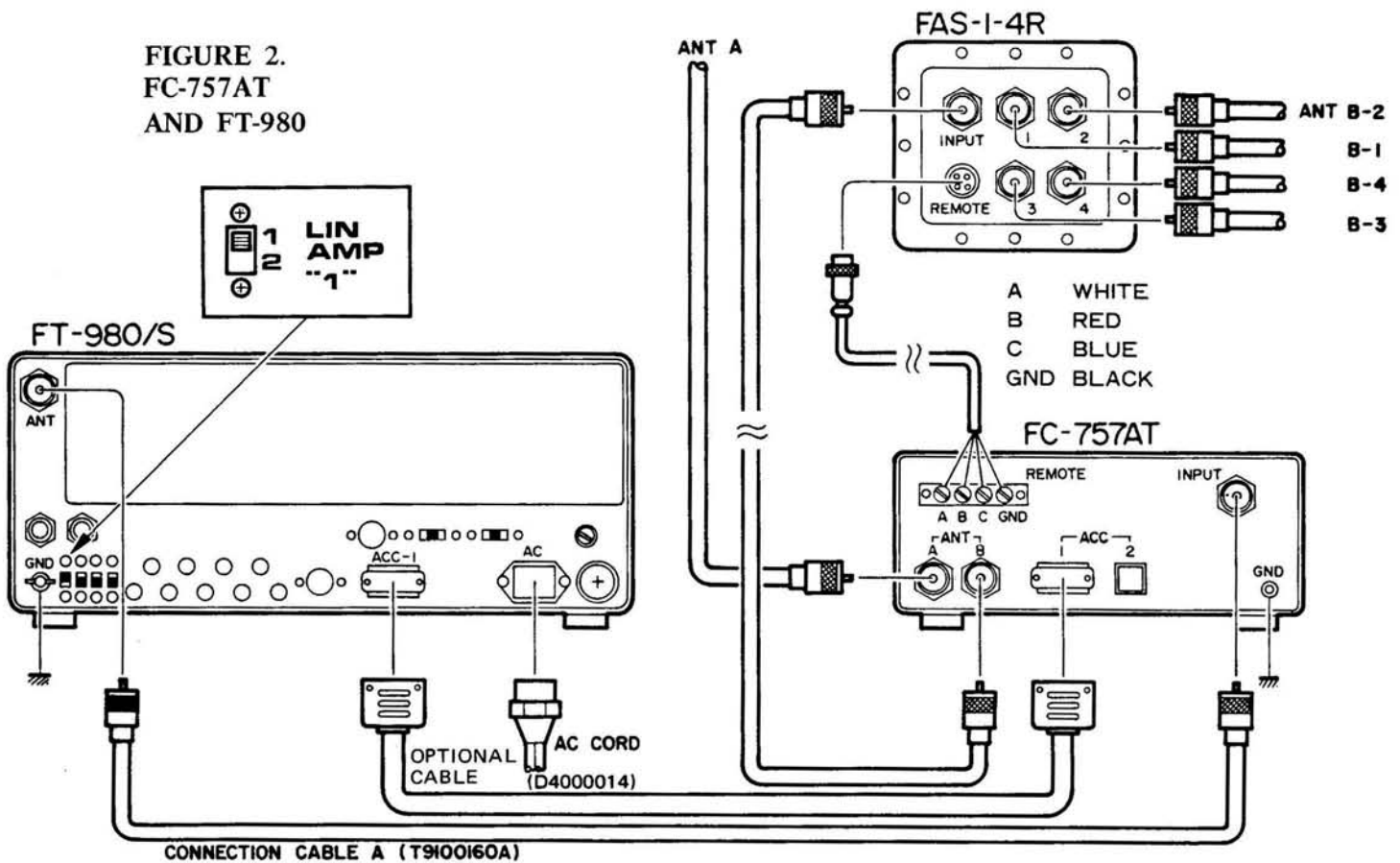

FIGURE 2.  
FC-757AT  
AND FT-980





## OPERATION

Before switching on power, recheck all interconnections as described on the previous pages. If using the FT-757GX with control cable C connected, depress the LIN AMP button on the rear panel of the transceiver. If using the FT-980 with the optional control cable connected, set the LIN AMP switch on the rear of the transceiver to position 1. This will allow the CPU in the FC-757AT to inhibit transmission automatically during band changes, and thus prevent possible damage to the band switch in the Tuner. For other installations where the FC-757AT is not remotely controlled, it is possible to utilize this feature by connecting the INH line from the Tuner to the TTL-level TX inhibit line of the transceiver, if available. Otherwise, extreme care must be taken at all times to avoid transmitting during band changing (while the WAIT indicator is lit). Also, avoid pressing the DUMMY or THRU switches, or manually changing bands or antennas while transmitting.

When the FC-757AT is connected for control by the transceiver, POWER switching and band selection is automatic as long as the POWER switch on the Tuner is on, and the MANUAL button is not depressed. Otherwise, power must be controlled by the FC-757AT POWER switch, and the MANUAL switch depressed. Band selection is then performed manually using the DOWN and UP keys on the Tuner, with the currently selected band indicated by the associated LED.

Switch the FC-757AT POWER switch on, and then switch the transceiver on. Tune the transceiver (and Tuner, if not connected for automatic control) to the desired operating band. The Tuner will adjust itself automatically for the frequency and load conditions last encountered on that band, and the WAIT indicator will be lit for about 10 seconds.

### Transceivers with vacuum tube amplifiers –

When using a transceiver that has tubes in the final amplifier circuit, such as the FT-902, FT-101ZD or FT-102, the final network in the transceiver must be tuned for a 50-ohm load before matching with the FC-757AT. To do this, press the DUMMY

button on the Tuner, and then key the transmitter and adjust the TUNE or PLATE and LOAD controls on the transceiver for 100 watts output and a dip in plate current as described in the operating manual for the transceiver. Do not exceed 30 seconds of transmission into the dummy load. If you need more time, let it cool for at least a minute before applying power again. Once the output circuit of the transceiver is tuned, press the DUMMY switch again to place the Tuner back in line, and proceed as follows.

### Auto-tune Matching

Once adjusted, the READY indicator will light, signifying that it is now okay to transmit. Now set the SENS control fully clockwise, and set the 15/150 METER switch to the 150 position (or the 15 position if operating with less than 15 watts). Set up the transceiver to send a CW carrier, and key the transmitter. If necessary, adjust the DRIVE or other power output control so that some transmitter ALC voltage can be observed on the ALC meter of the transceiver.

### NOTE:

If the red WARNING indicator lights, stop transmitting immediately and check the antenna and feedline connections for a short or open circuit. Do not proceed until the cause is located and the fault corrected.

Now press the START button while transmitting the carrier, and note that the WAIT indicator lights again. The auto-tune circuit is now functioning, and if you have the SWR/PO switch set to SWR, you will see the auto-tuning seek the point of minimum SWR. As long as the selected antenna is not too far from resonance at the operating frequency, the WAIT indicator will extinguish when auto-tuning is complete, and the READY indicator will again light. SWR seen by the transmitter is now 1.5:1 or less.

If the antenna is far from resonance (or if antenna Q is high), and especially if you are using a transceiver that has a broadband solid state power amplifier, the automatic final protection circuitry in the transceiver may interfere with the auto-tune system. This is because the output protection circuitry automatically reduces the power of the transmitter when the SWR is high, and such power reduction may mislead the auto-tune sensors. In this case, rotate the SENS control slightly counterclockwise, and allow the auto-tune system to adjust minimum SWR at the lower SENSitivity setting. When the READY indicator lights, rotate the SENS control to the fully clockwise position, return to receive for a moment, then transmit again. Any residual SWR will then be tuned out, if necessary.

When the SENS control is set fully clockwise, any time that the transmitter is activated and the SWR is about 1.5:1, the auto-tune system will seek to retune the antenna. This will occur if the transmitter is retuned to a different frequency, or if any changes in SWR appear in the antenna (due to repositioning, weather changes, etc.). Therefore, for mobile operation, the auto-tune system must be desensitized once the antenna has been matched. To do this, set the SENS control fully counterclockwise.

### Manual Matching

If you think you can match the antenna better than the auto-tune system, if the auto-tune system cannot find the match, or if you wish to use the Tuner to match an antenna for receiving only, manual impedance adjustment is possible.

When using a transmitter on the amateur bands, set the SENS control fully counterclockwise to disable the auto-tune system, and set the METER SWR/PO switch to the PO (undepressed) position. Now transmit a carrier while pressing the four TUNE and LOAD buttons (one at a time) while watching the PO meter indication for maximum deflection. When this is obtained, press the METER SWR/PO switch to the SWR position, and make sure that the SWR is below 3:1. Return the transceiver to receive. If the SWR indicated above 3:1, it might be possible to obtain a better match on another band setting. To do this, set the MANUAL button to the depressed position, press the DOWN or UP button, key the transmitter and repeat the adjustment for maximum PO. If the SWR cannot be brought below 3:1 in any band setting or adjustment of the tuner, or if the WARNING indicator is lit, do not use that particular antenna for transmitting at that frequency.

Manual adjustment settings will be stored in memory when changing bands, just like automatic settings.

### Receive-Only Matching

The automatic and manual matching techniques described above must not be used for operating frequencies that are outside of the frequency ranges in which the operator is authorized to transmit, since it is necessary to apply power to the antenna in both methods. However, the FC-757AT may be used manually to match antennas for reception only, on frequencies outside of the authorized bands. To do this, simply tune the receiver to an AM station that is relatively free from fading, set the receiver AGC to the fast position, and press the four TUNE and LOAD buttons

### TUNE and LOAD Adjustment Sequence

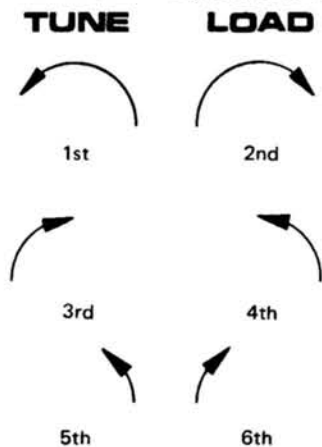

These are the six steps used by the auto-tune system. They can be duplicated manually with the four TUNE and LOAD buttons.

(one at a time) to obtain the highest possible signal strength indication on the receiver S-meter.

In some cases, such as when receiving on a frequency far from an amateur band, or using an antenna that is far from resonance, it may not be possible to obtain a good S-meter peak. If this occurs, press the THRU button to bypass the Tuner circuit, to determine if the antenna provides a stronger signal in the receiver when connected directly.

**FT-980 Users –**

When operating on the GEN mode, the Tuner will be automatically set to THRU (bypass) internally, via the control cable, unless the MANUAL button on the FC-757AT is pressed.

**Automatic Memory System and Backup**

When you have tried the FC-757AT on several bands, it should become obvious that the microprocessor in the Tuner is recalling the previous tuner settings used on each band whenever it is selected. Also, if you are using several different antennas, you will notice that the antenna last selected for each band is also automatically re-selected when returning to that band.

The Tuner settings and selected antenna data are stored in RAM, and retained by a lithium backup battery which is normally switched on at the factory. Current drain is so small that the lithium battery should last at least five years, if left on all the time. However, if it is necessary to store the FC-757AT for a long period of time, the backup system may be switched off by moving the backup switch on the CPU Unit (beneath the top cover) to the right. All information in the memory will thus be cleared. See page 16 for the location of the backup switch.

**FAS-1-4R REMOTE ANTENNA SELECTOR**

The FAS-1-4R Remote Antenna Selector may be installed at the feedpoints of the antennas providing selection between up to four antennas using only one coaxial feedline and control cable between the FC-757AT and Selector. Heavy duty relays are used to enable good isolation at RF power levels up to 1.2 kW PEP (though RF power must be limited to 150W when the feedline is connected to the FC-757AT).

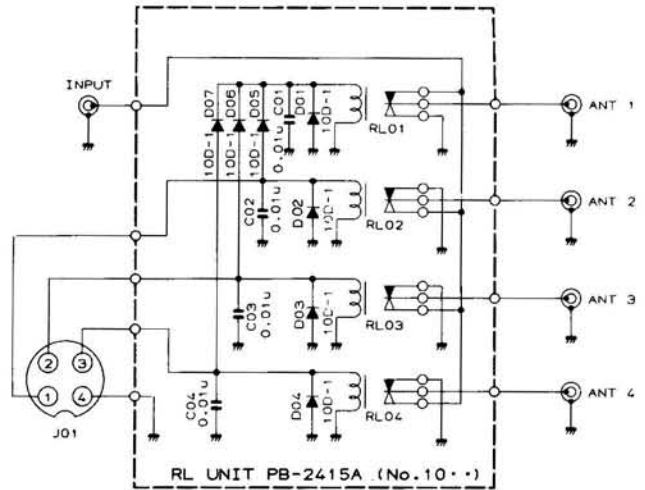

**FAS-1-4R Schematic Diagram**

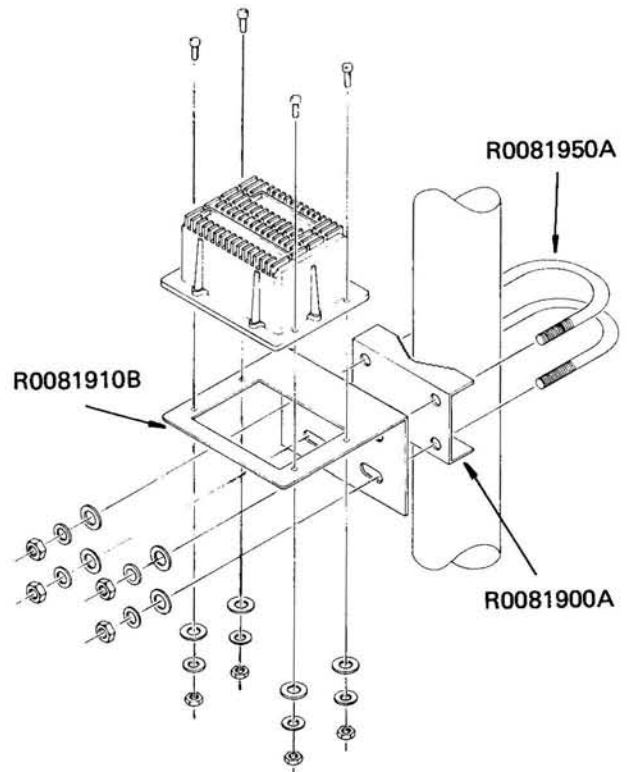

**Figure 1**

**Table 1**  
**CONTROL CABLE CONNECTIONS**

TERMINAL	PLUG PIN NO.
A . . . . .	1 (White)
B . . . . .	2 (Red)
C . . . . .	3 (Blue)
GND . . . . .	4 (Black)

**Installation at Remote Location**

1. Bolt the FAS-1-4R to the angle bracket using the four screws, nuts and washers as shown in Figure 1.
2. Referring to Figures 2 and 3, cut the small end of each weather sleeve to the correct size to provide a tight fit around the cables being used – one for each coax and one for the control cable. Then slide the sleeves over the cables and solder the wires to the connectors. The wiring of the control cable is indicated in Table 1.
3. Using the U-bolt and Mast Clamp supplied, mount the FAS-1-4R on the tower or support mast (mast diameter must be 37–64 mm, or different hardware will be required).
4. Mate the connectors, one at a time, with their jacks on the FAS-1-4R, applying sealing compound around each mated fitting after the weather sleeve has been slid over the connector (Figure 4).

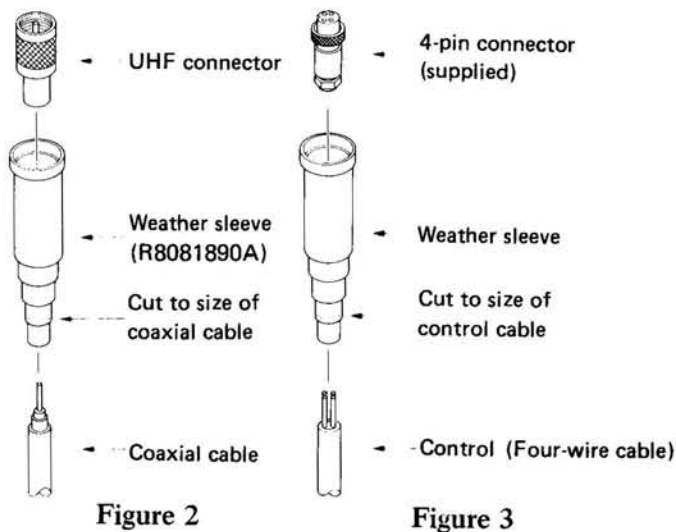

**NOTE:** Use short feeder lengths of 50-ohm coaxial cable to connect the antenna feedpoints to the FAS-1-4R. The antenna feedpoints should be unbalanced (using baluns, if necessary), and as close as possible to 50-ohms at the intended operating frequencies for best results.

**Interconnection with the FC-757AT**

Connect the main coaxial feedline from the INPUT jack on the FAS-1-4R to the ANT B terminal on the FC-757AT, and connect the wire ends of the 4-conductor cable from the REMOTE jack on the FAS-1-4R to the REMOTE terminal strip on the FC-757AT, as indicated in Table 1.

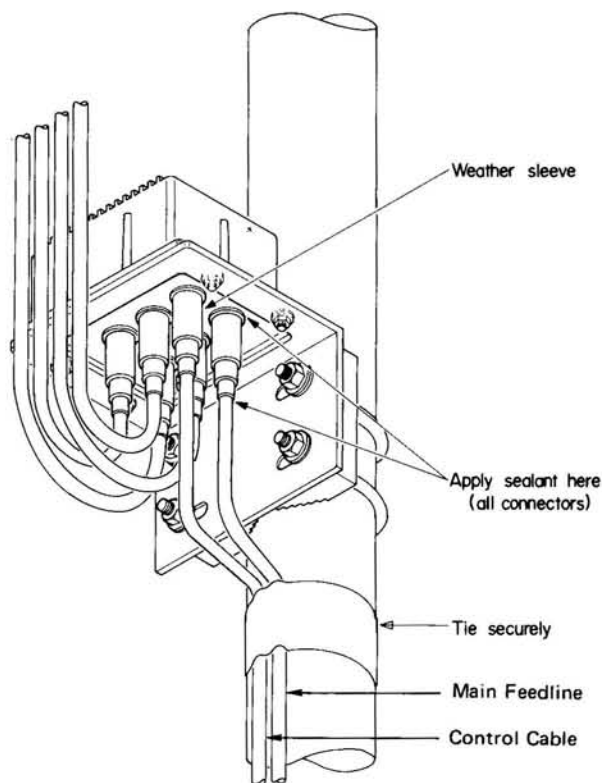

**Figure 4**

## ALIGNMENT

The FC-757AT has been carefully aligned at the factory, and with normal use it should not require realignment, although the lithium battery may require replacement after five years. This section describes the procedures used to align the FC-757AT before it leaves the factory, and these should not need to be repeated except in the event of component failure. Should this occur, the FC-757AT should be returned to the dealer from whom it was purchased for repair, at which time the necessary realignments will also be carried out.

Failures caused by unauthorized attempts at alignment are generally not covered by the warranty policy, so any such attempts must be at the customer's own risk.

The following tools and equipment are required for alignment:

One 17-ohm non-reactive dummy load (or three 50-ohm dummy loads connected in parallel)

One 50-ohm non-reactive dummy load

In-line RF wattmeter with 20 and 200W ranges and 5% accuracy at 14 MHz.

1.5 mm hex Allen wrench (for setscrews).

HF transmitter or transceiver capable of 10 and 100W output on the 14 MHz band.

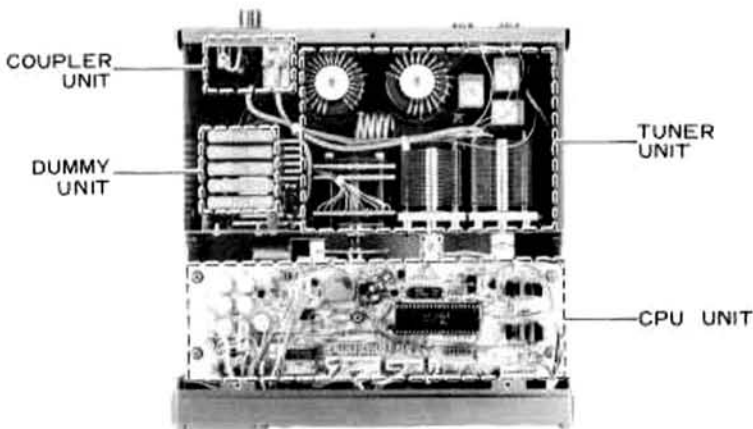
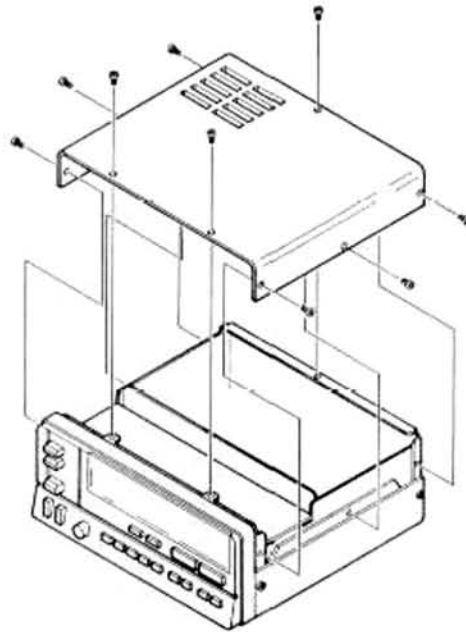

TOP VIEW

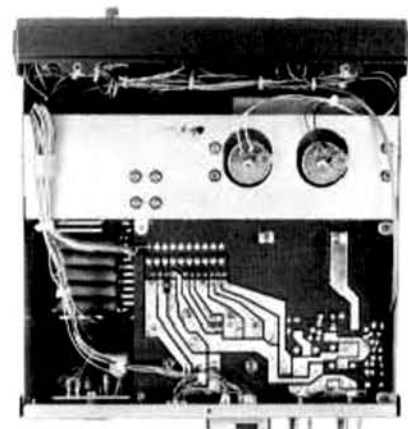

BOTTOM VIEW

## CM Coupler Balance

1. Connect the inline wattmeter with 50-ohm dummy load to the ANT A jack, and set the FC-757AT and transceiver to the 14 MHz band. On the FC-757AT, press the ANTENNA A button, and set the THRU switch to the depressed position and the SWR/PO switch to the SWR (depressed) position.
2. Adjust the transmitter to provide 100W steady CW, and then with the PTT line closed, adjust TC<sub>301</sub> (rear left corner of the chassis) for minimum deflection on the FC-757AT meter.

This procedure must be repeated after the PO Meter and SWR Meter alignments have been performed.

## PO Meter Calibration

1. First perform the previous CM Coupler Balance procedure.
2. Set the SWR/PO switch to the PO (undeepressed) position, and with the METER 15/150 switch in the 150 (undeepressed) position, key the transmitter and adjust VR<sub>104</sub> on the CPU Unit so that the power indications on the internal and external wattmeters coincide at 100 watts.
3. Release the PTT switch and change the scale of the external wattmeter to the lower range. Press the 15/150 button to change the internal wattmeter to the 15-watt range. Reduce the transmitter power to 10 watts, and then key the transmitter and adjust VR<sub>103</sub> on the CPU Unit so that the power indications on both meters again agree, at 10 watts.

## SWR Meter Calibration

The CM Coupler Balance and PO Meter alignment procedures must be performed before proceeding.

1. Note the required settings on the transmitter to produce 10 watts and 100 watts output into 50 ohms, and then replace the 50-ohm load with the 17-ohm dummy load.

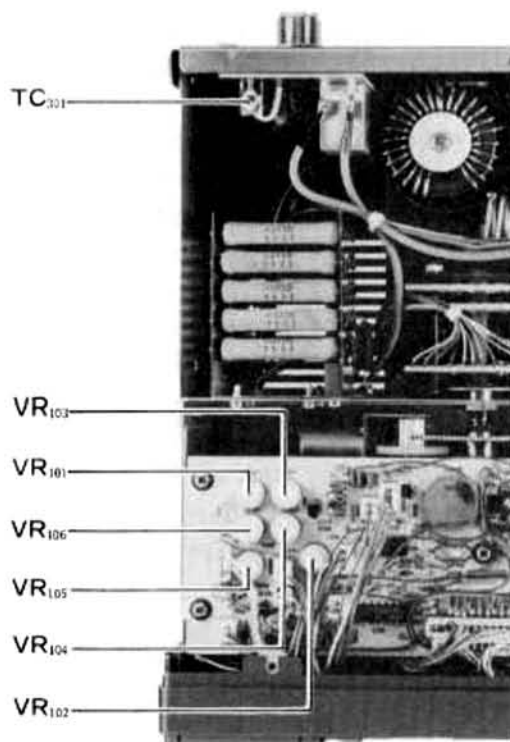

2. Preset VR<sub>101</sub> on the CPU Unit fully counterclockwise, and VR<sub>102</sub> fully clockwise. Set the METER SWR/PO switch to the SWR position, and the 15/150 switch to the 150 position. Set the transmitter controls to the 100-watt positions (determined in the previous step).
3. Key the transmitter and adjust VR<sub>101</sub> clockwise just to the threshold point where the SWR meter indication begins to decrease. Then adjust VR<sub>102</sub> so that the meter indicates exactly 3 (-to-1).
4. Now reduce the transmitter power to the 10-watt positions, and check that the SWR meter indication is near 3. If it has changed much, carefully readjust VR<sub>101</sub> for the threshold point, and VR<sub>102</sub> for the midscale deflection. Repeat the adjustments at 100 and 10 watts until the indicated SWR, when set to 3 at 100 watts, is between 2 and 3.3 (10 and 25 on the 150W PO scale) at 10 watts. If necessary, increase power to 15 or 20 watts for the low power check.
5. Repeat the CM Coupler Balance procedure.

## Variable Capacitor Presetting

This procedure involves a combination of mechanical and electrical adjustments that determines the position-sensing parameters used by the CPU to control TUNE and LOAD capacitors  $VC_{201}$  and  $VC_{202}$  via the resistance of sensor potentiometers  $VR_{01}$  and  $VR_{02}$  on the motor-driven shafts.  $VR_{105}$  and  $VR_{106}$  on the CPU Unit are used to preset the sensor voltages for the TUNE and LOAD controls, respectively, after the mechanical settings have been made, and all setscrews tightened.

1. Loosen the setscrews in the nylon shaft couplers on the sides of the shafts of  $VC_{201}$ ,  $VC_{202}$ ,  $VR_{01}$  and  $VR_{02}$ , using the 1.5 mm Allen wrench.
2. Set  $VC_{201}$  and  $VC_{202}$  to their fully meshed positions, and tighten the two associated setscrews on their shafts.
3. Set  $VR_{01}$  and  $VR_{02}$  both fully counterclockwise (viewed from the rear, shaft side), and tighten the two associated setscrews on their shafts.
4. Press the TUNE “▷” button and observe the position of  $VC_{201}$  when it stops. If this is not the point of minimum capacitance, adjust  $VR_{105}$  on the CPU Unit (the motor will move the capacitor automatically).
5. Press the TUNE “◁” button and note the position of  $VC_{201}$  when it again stops. If this is not the point of maximum capacitance (fully meshed plates), loosen the shaft coupler and reposition  $VC_{201}$ . Then tighten the setscrew again and repeat steps 4 and 5.
6. Follow the same procedure as in steps 4 and 5 to adjust LOAD capacitor  $VC_{202}$ , using  $VR_{106}$  on the CPU Unit to set the point of minimum capacitance.

## Backup Battery Replacement

To determine whether the lithium backup battery needs to be replaced, measure the DC voltage between the top of the battery (exposed side) and ground. If this is 2.0 volts or less, the battery should be replaced. Use a Sony type CR2025-WT1 or Sanyo CR2025. New battery voltage is 3 volts. Use care not to short circuit either new or old batteries.

1. Switch the POWER switch off, and set backup switch  $S_{101}$  (as shown below) on the CPU Unit off. Remove the five screws affixing the CPU Unit.
2. Unsolder the terminals of the old battery, and install the new battery in the same manner. Then replace the CPU Unit and its five screws.
3. Set the POWER switch ON first, and then reset  $S_{101}$  to the left (on) position. **DO NOT TURN THE BACKUP SWITCH ON FIRST.**

All data previously stored has now been erased, so remember to reset the antenna selector switches for the proper bands before rematching.

### CPU UNIT

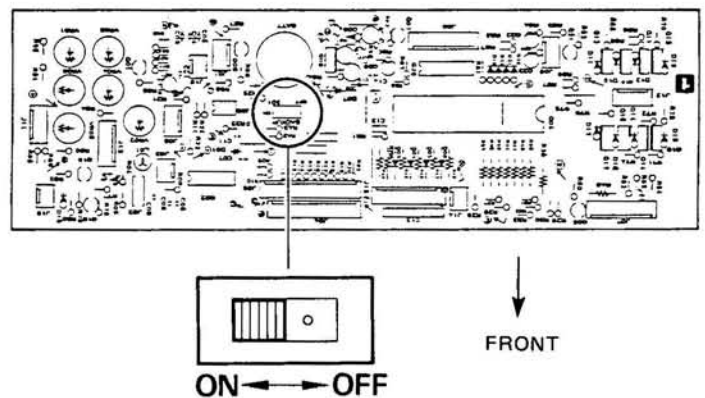

# MAIN SCHEMATIC DIAGRAM

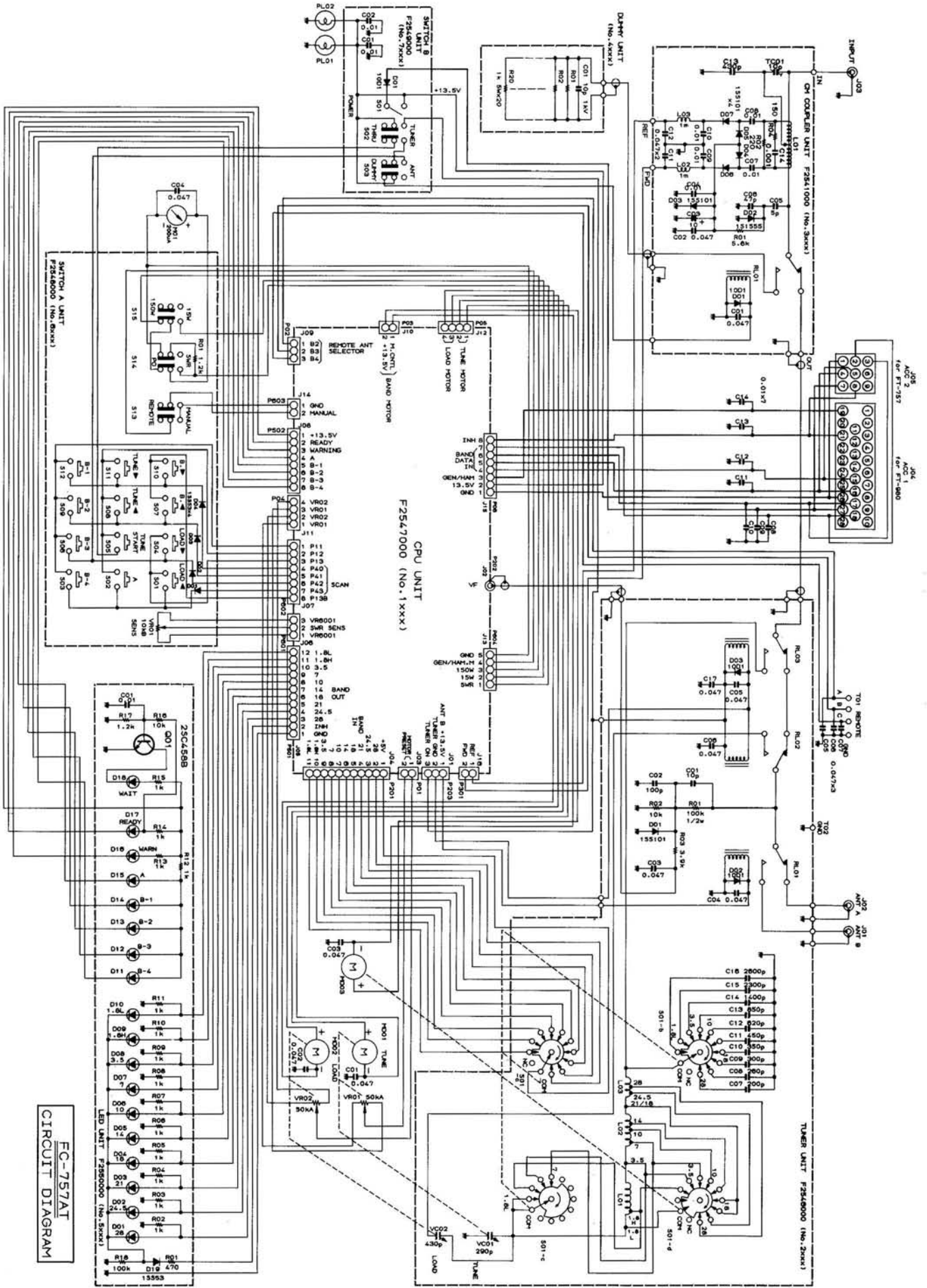

FC-757AT  
CIRCUIT DIAGRAM

# CPU UNIT SCHEMATIC DIAGRAM

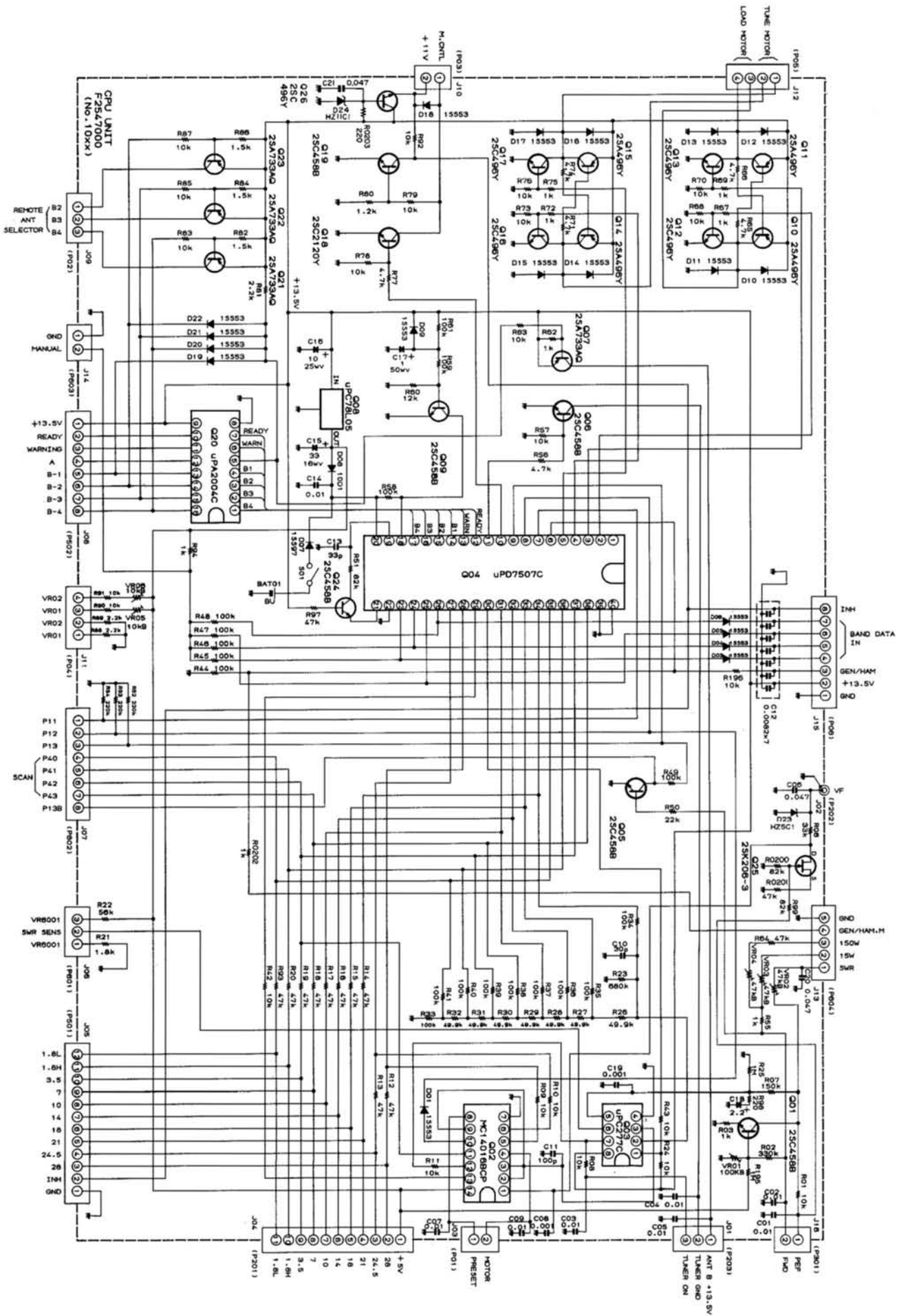

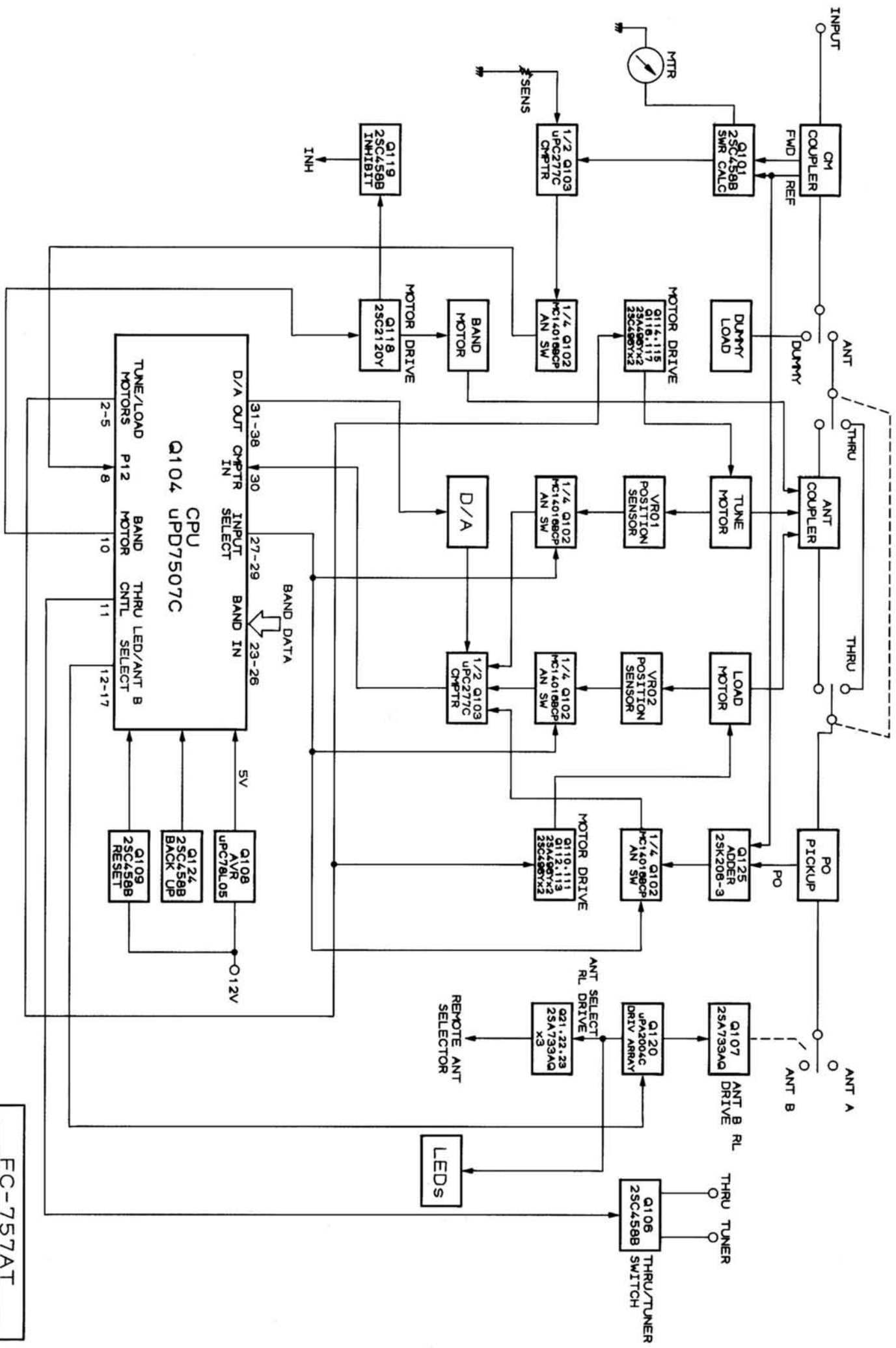

FC-757AT  
BLOCK DIAGRAM



R112-120,164, 193,0201	J02245473	Carbon film 1/4W SJ 47k $\Omega$			<b>LITHIUM BATTERY</b>
R197	J01245473	" " " TJ 47k $\Omega$	BAT101	Q9000106	CR-2025
R122	J02245563	" " " SJ 56k $\Omega$			
R151,199,0200	J02245823	" " " " 82k $\Omega$			
R144-149	J01245104	" " " TJ 100k $\Omega$			
R158,159,161	J02245104	" " " SJ 100k $\Omega$			
R107	J02245154	" " " " 150k $\Omega$			
R152-154	J02245224	" " " " 220k $\Omega$			
R102	J02245334	" " " " 330k $\Omega$	Symbol No.	Part No.	Description
R123	J02245684	" " " " 680k $\Omega$		F2546000	Printed Circuit Board
R125	J02245105	" " " " 1M $\Omega$		C025460A	PCB with components
R195	J01245105	" " " TJ 1M $\Omega$			
					<b>TUNER UNIT</b>
		<b>POTENTIOMETERS</b>	D201	G2090223	Schottky Barrier 1SS101
VR105,106	J51723103	H1051A013-10KB 10k $\Omega$ B	D202,203	G2090001	Si 10D1
VR102-104	J51723473	H1051A017-47KB 47k $\Omega$ B			
VR101	J51723104	H1051A019-100KB 100k $\Omega$ B			
					<b>DIODES</b>
					<b>RESISTORS</b>
			R203	J02245392	Carbon film 1/4W SJ 3.9k $\Omega$
			R202	J02245103	" " " " 10k $\Omega$
			R201	J02245104	" " " " 100k $\Omega$
					<b>CAPACITORS</b>
C110	K00179007	Ceramic disc 50WV SL 30pF (DD104SL300J50V)			
C113	K02175330	" " " CH 33pF (DD105CH330J50V)			
					<b>CAPACITORS</b>
C111	K00175101	" " " SL 100pF (DD105SL101J50V)	C203-206,217	K13179009	Ceramic disc 50WV F 0.047 $\mu$ F (DD110F473Z50V)
C108,119	K10176102	" " " B 0.001 $\mu$ F (DD104B102K50V)	C201	K30275100	Dipped Mica 500WV 10pF (LCQ11100J5)
C101-105,107, 109,114	K13179008	" " " F 0.01 $\mu$ F (DD106F103Z50V)	C202	K30275101	" " " 100pF (LCQ12101J5)
C106,120,121	K13179009	" " " " 0.047 $\mu$ F (DD110F473Z50V)	C207	K30309026	" " 1KWV 200pF (DML2 201J10)
C117	K40179013	Electrolytic 50WV 1 $\mu$ F (50RE1)	C208	K30309027	" " " 260pF (DML2 261J10)
C118	K40179009	" " 2.2 $\mu$ F (50RE2R2)	C209	K30309011	" " " 300pF (DML2 301J10)
C116	K40149008	" 25WV 10 $\mu$ F (25RE10)	C210	K30309028	" " " 350pF (DML2 351J10)
C115	K40129008	" 16WV 33 $\mu$ F (16RE33)	C211	K30309029	" " " 450pF (DML2 451J10)
			C212	K30309030	" " " 620pF (DML2 621J10)
					<b>BLOCK CAPACITOR</b>
C112	K80000005	50WV 0.0082 $\mu$ F x 7 (B8ZC0111-32N)	C213	K30309031	" " " 850pF (DML2 851J10)
			C214	K30309032	" " " 1400pF (DML2 142J10)
			C215	K30309033	" " " 2300pF (DML2 232J10)
			C216	K30309034	" " " 2600pF (DML2 262J10)
					<b>SWITCH</b>
SI01	N6090037	SSS-312049			<b>VARIABLE CAPACITOR</b>
			VC201	K90000041	YB-290-SL8 (TUNE)
			VC202	K90000042	YB-430-SL8 (LOAD)
					<b>CONNECTORS</b>
J103,110,114,116	P0090191	B2B-XH-A			
J101,106,109	P0090192	B3B-XH-A			<b>INDUCTORS</b>
J111,112	P0090193	B4B-XH-A	L201	L0021391	
J113	P0090194	B5B-XH-A	L202	L0021392	
J107,108,115	P0090197	B8B-XH-A	L203	L0021393A	
J104	P0090200	B11B-XH-A			
J105	P0090201	B12B-XH-A			
J102	P1090255	TMP-JA			

RELAYS			RELAY		
RL201-203	M1190026		RL301	M1190026	MR-31 12V
SWITCH					
S201	N0050069A	SR32HP3-3-10			
PLUGS			DUMMY LOAD UNIT		
P201	T9204746	XHP-11	Symbol No.	Part No.	Description
P202	T9311801	TMP	R401-420	J22375102	RESISTORS Metallic film 5W 1k $\Omega$ (RSF-5BJ)
P203	T9204747	XHP-3			
TERMINAL			CAPACITOR		
	Q5000011	Wrapping C	C401	K31306100	Molded Mica 1KWV 10pF (CML1 100K10)
	Q5000036	TP-G			
CM COUPLER UNIT			LED UNIT		
Symbol No.	Part No.	Description	Symbol No.	Part No.	Description
	F2541000	Printed Circuit Board		F2550000	Printed Circuit Board
	C025410A	PCB with components		C025500A	PCB with components
DIODES			TRANSISTOR		
D301	G2090001	Si 10D1	Q501	G3304580C	2SC458C
D302	G2015550	" 1S1555			
D303-307	G2090223	Schottky Barrier 1SS101			
RESISTORS			DIODES		
R304	J01245151	Carbon film 1/4W TJ 150 $\Omega$	D501-510,515,517	G2090267	LED SG238D
R302	J02245221	" " " SJ 220 $\Omega$	D511-513,514,518	G2090268	" SY438D
R301	J02245562	" " " " 5.6k $\Omega$	D516	G2090269	" SR538D
			D519	G2090027	Si 1SS53
CAPACITORS			RESISTORS		
C305	K02279002	Ceramic disc 500WV CH 5pF (ECC-D2H050DC)	R501	J02245471	Carbon film 1/4W SJ 470 $\Omega$
C306	K00175470	" " 50WV SL 47pF (DD104SL470J50V)	R502-515	J02245102	" " " " 1k $\Omega$
C314	K10176102	" " " B 0.001 $\mu$ F (DD104B102K50V)	R517	J02245122	" " " " 1.2k $\Omega$
C304,307-310	K13179008	" " " F 0.01 $\mu$ F (DD106F103Z50V)	R516	J02245103	" " " " 10k $\Omega$
C301,302,311,312	K13179009	" " " " 0.047 $\mu$ F (DD110F473Z50V)	R518	J02245104	" " " " 100k $\Omega$
C313	K30275431	Dipped Mica 500WV 430pF (LCQ18431J5)	SWITCH A UNIT		
C303	K40169012	Electrolytic 35WV 10 $\mu$ F (35RE10)	Symbol No.	Part No.	Description
TRIMMER CAPACITOR				F2548000	Printed Circuit Board
TC301	K91000019	ECV-1ZW10x40 10pF		C025480A	PCB with components
INDUCTORS			DIODES		
L301	L0021347		D601-604	G2090027	Si 1SS53
L302,303	L1190017	FL5H102K 1mH			
RESISTOR					
			R601	J01245122	Carbon film 1/4W TJ 1.2k $\Omega$



